

W11.03 Resistor Circuits 3

For each of the following circuits, find the total equivalent resistance of the circuit. Also find the current through and voltage drop across each resistor. Finally, find the power dissipated by each resistor.

1)

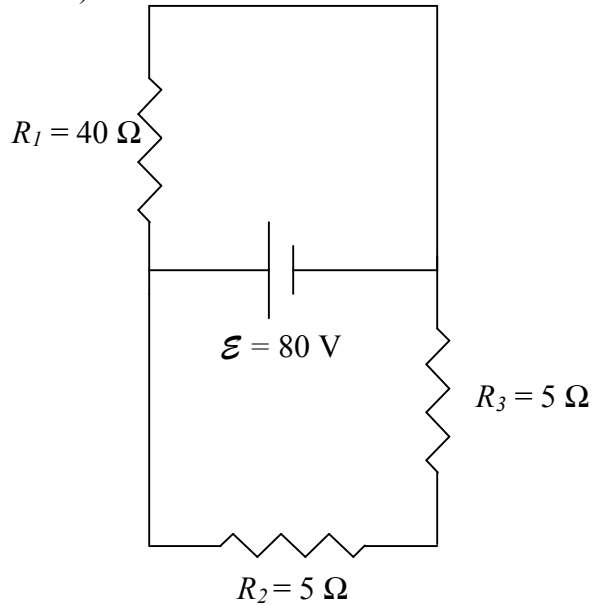

3)

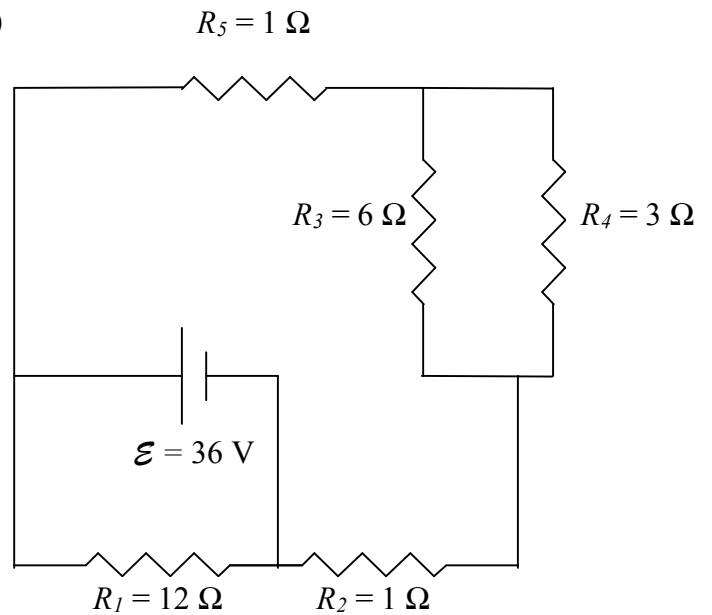

2)

